

PLEASE READ this sheet prior to assembly to familiarise yourself with the various stages of construction. Carefully open the pack supplied and check the contents against the parts and fittings check list.

Do not destroy any of the packaging until you are certain that you have all the necessary parts for the assembly.

Please ensure that the packaging is disposed of in a safe environmentally friendly way.

CAUTION: There are small components used in the construction of this unit. These loose items should be kept away from young children during assembly, to avoid the danger of choking.

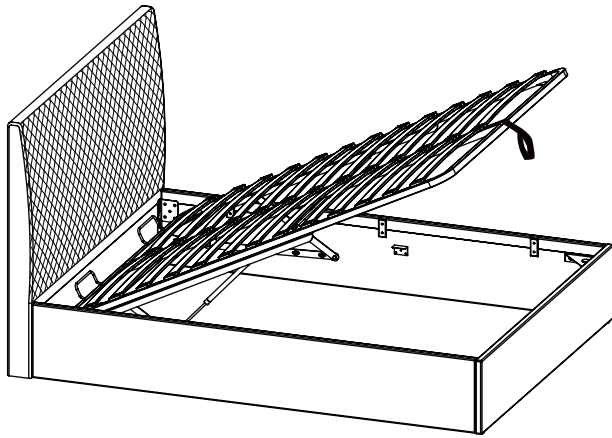

IMPORTANT: BEFORE STARTING TO ASSEMBLE THE BED - PLEASE READ THESE INSTRUCTIONS CAREFULLY.



An instructional video of the Operation of the Ottoman Lift Up system is available via YouTube using the following address: https://youtu.be/hyq4zm7h_yU

Parts Identification

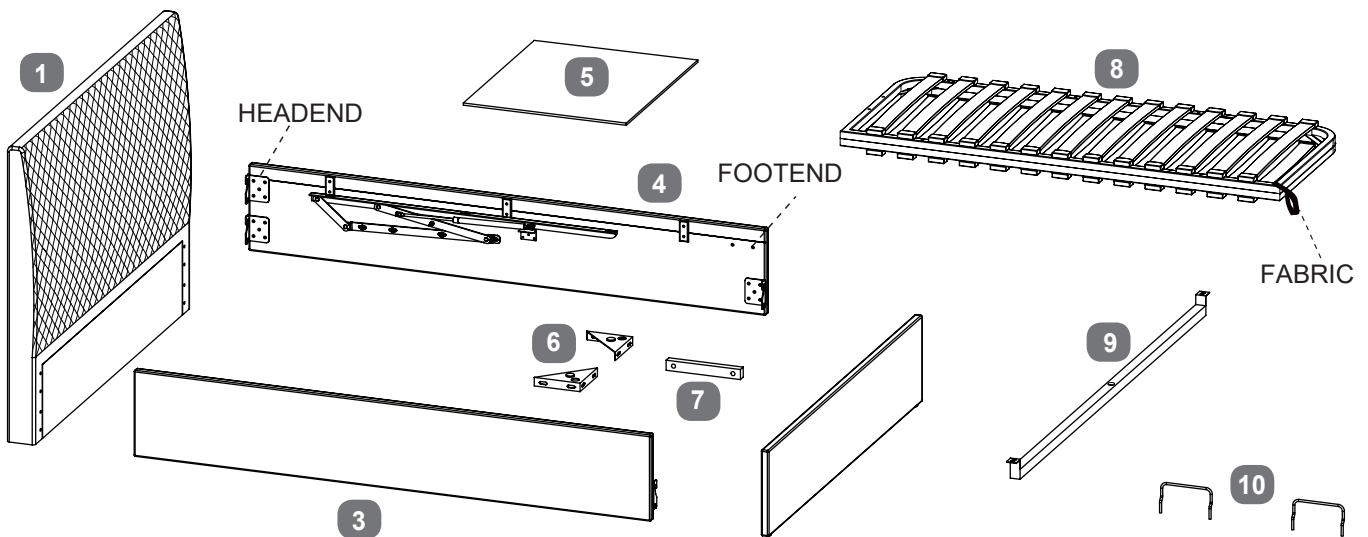

Parts Checklist

Ref.	Description	Qty	Ref.	Description	Qty
1	Headboard	1	6	Angle Brackets	2
2	Footboard	1	7	Slat Frame Support Rail	1
3	Side Rail - Left	1	8	Metal Slat Frame	1
4	Side Rail - Right	1	9	Cross Bar	1
5	Base Fabric Cover	1	10	Mattress Stoppers	2

Fittings Checklist

HARDWARE NEEDED FOR BED ASSEMBLY (PACK A)

Ref.	Description	Qty	Ref.	Description	Qty
A	Bolts (M8x30mm) for fitting side rails (3&4) and to headboard & footboard (1&2)	x20	D	Allen Key (for M8 bolt)	x1
B	Spring Washers (for M8 bolts)	x20	E	Bolts (M8x50mm) for fitting Slat Frame Support Rail (6) to Footboard (2)	x2
C	Flat Washers (for M8 bolts)	x22			

HARDWARE FOR FITTING METAL SLAT FRAME (PACK B)

Ref.	Description	Qty	Ref.	Description	Qty
B	Spring Washers (for M8 bolts)	x12	G	Spanner (for M8 nut)	x1
C	Flat Washers (for M8 bolts)	x18	H	Flange Lock-Nuts (M8) for gas-lift pistons	x2
E	Bolts (M8x50mm) for fitting Metal Slat Frame (10) to slat frame support bars	x6	J	Bolts (M8x20mm) for fitting Metal Plates (K) and Cross Bar (9) to Metal Slat Frame (8)	x6
F	Nuts (for M8 slat frame bolts)	x6	K	Metal Plates for Slat Frame	x2

Additional Tools Required

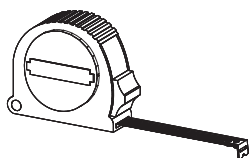

Care & Maintenance

In the unlikely event of missing or damaged parts, please contact your retailer. Please have this guide at hand quoting the part code reference numbers shown when requesting spare or replacement parts.

General Hints & Tips



Please retain your assembly instruction and tools provided for future use. Periodically check that all bolts are still tight.



Assembly requires two persons.



1.5 Hrs

Approximate time to assemble this product

Bed Assembly - Use Pack 'A'

Stage
1

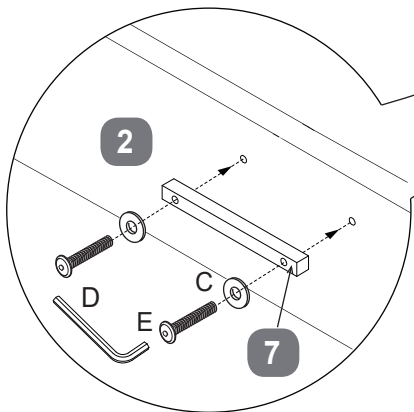
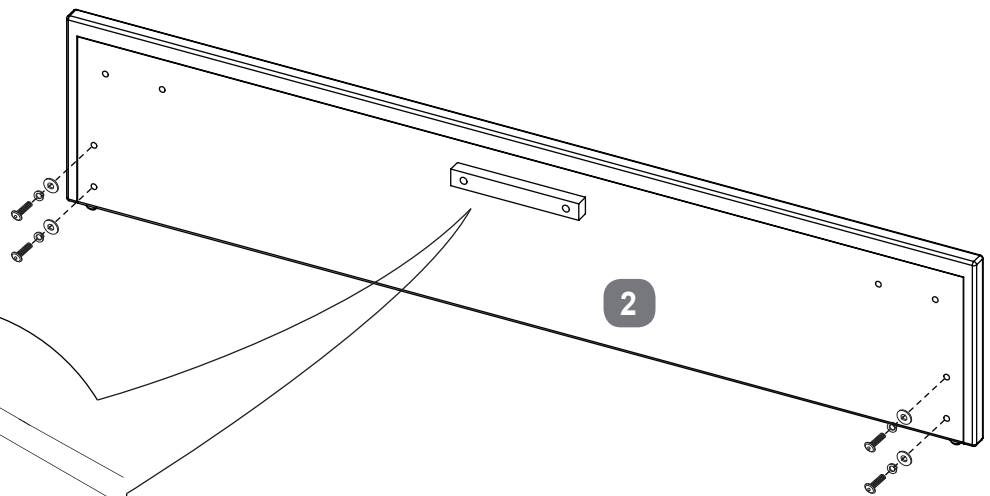
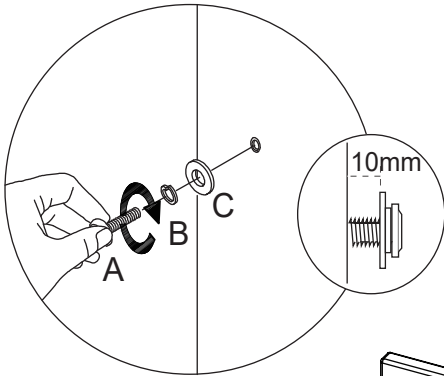
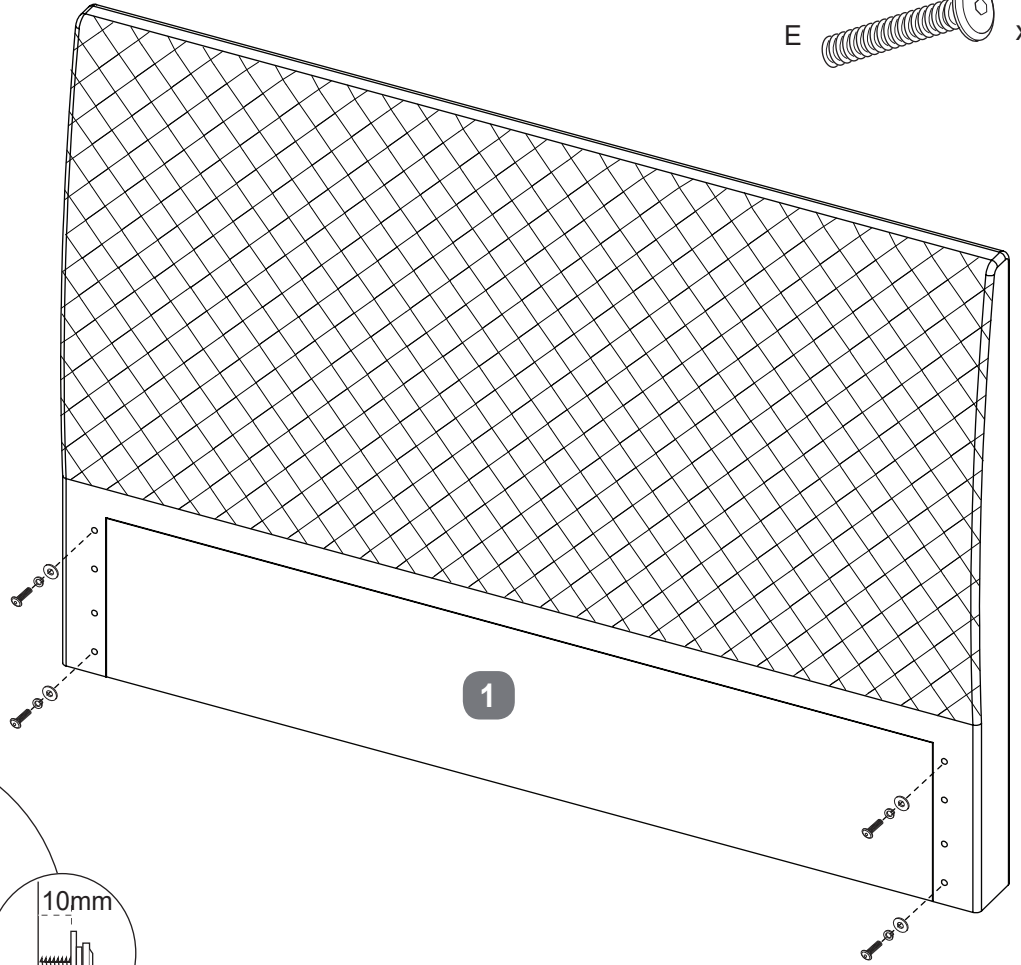
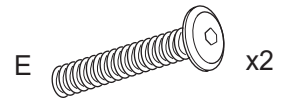
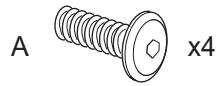

Fit slat frame support rail (9) to footboard using two bolts (E) & flat washers (C).
Using Allen Key (D) tighten 100%.

Bed Assembly - Use Pack 'A'

Stage
2

- A  x4 B  x4 C  x4 D  x1

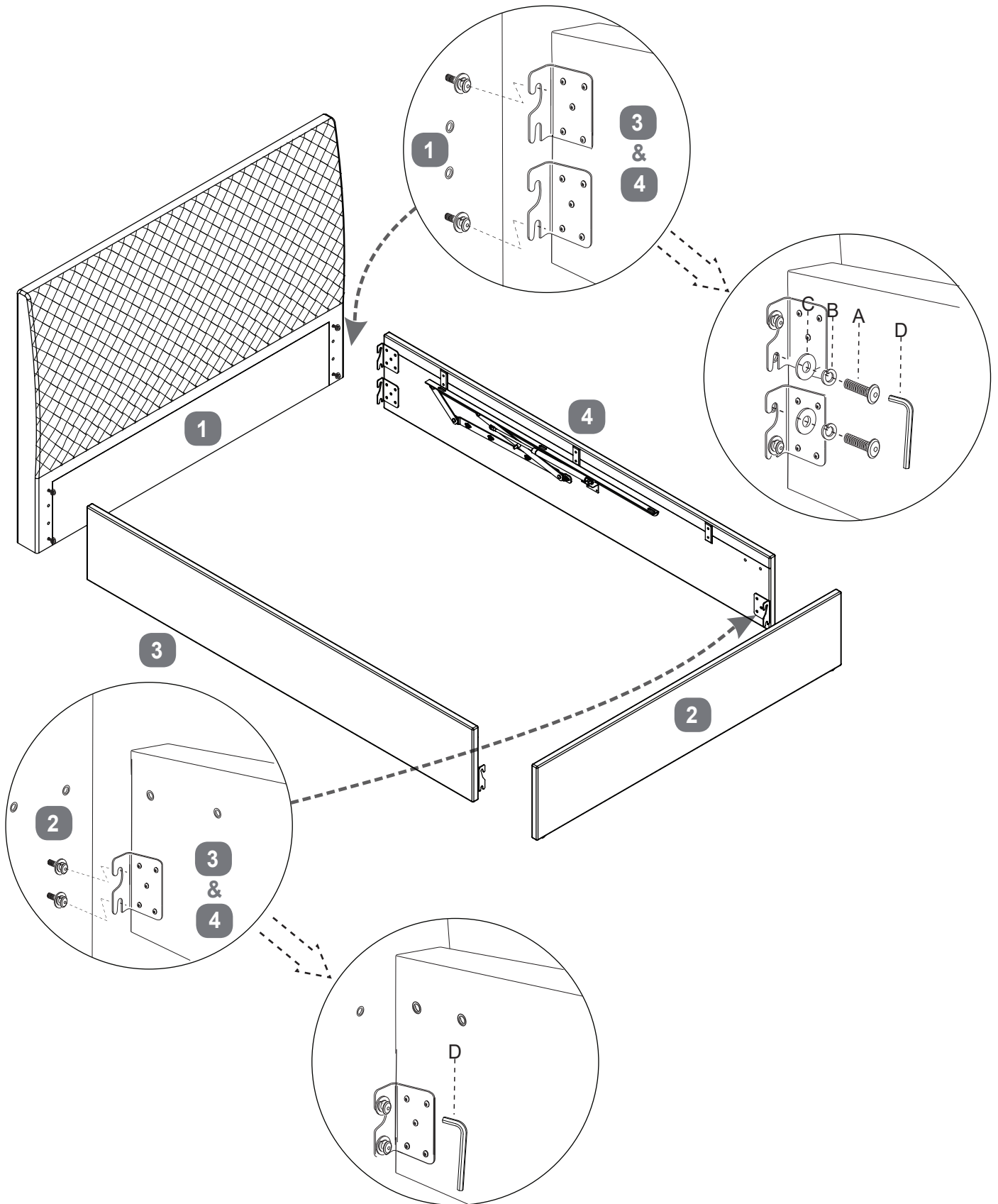

Loosely screw in the bolts but do not tighten them 100% yet.

Bed Assembly - Use Pack 'A'

Stage
3

- A  x8
- B  x8
- C  x8
- D  x1

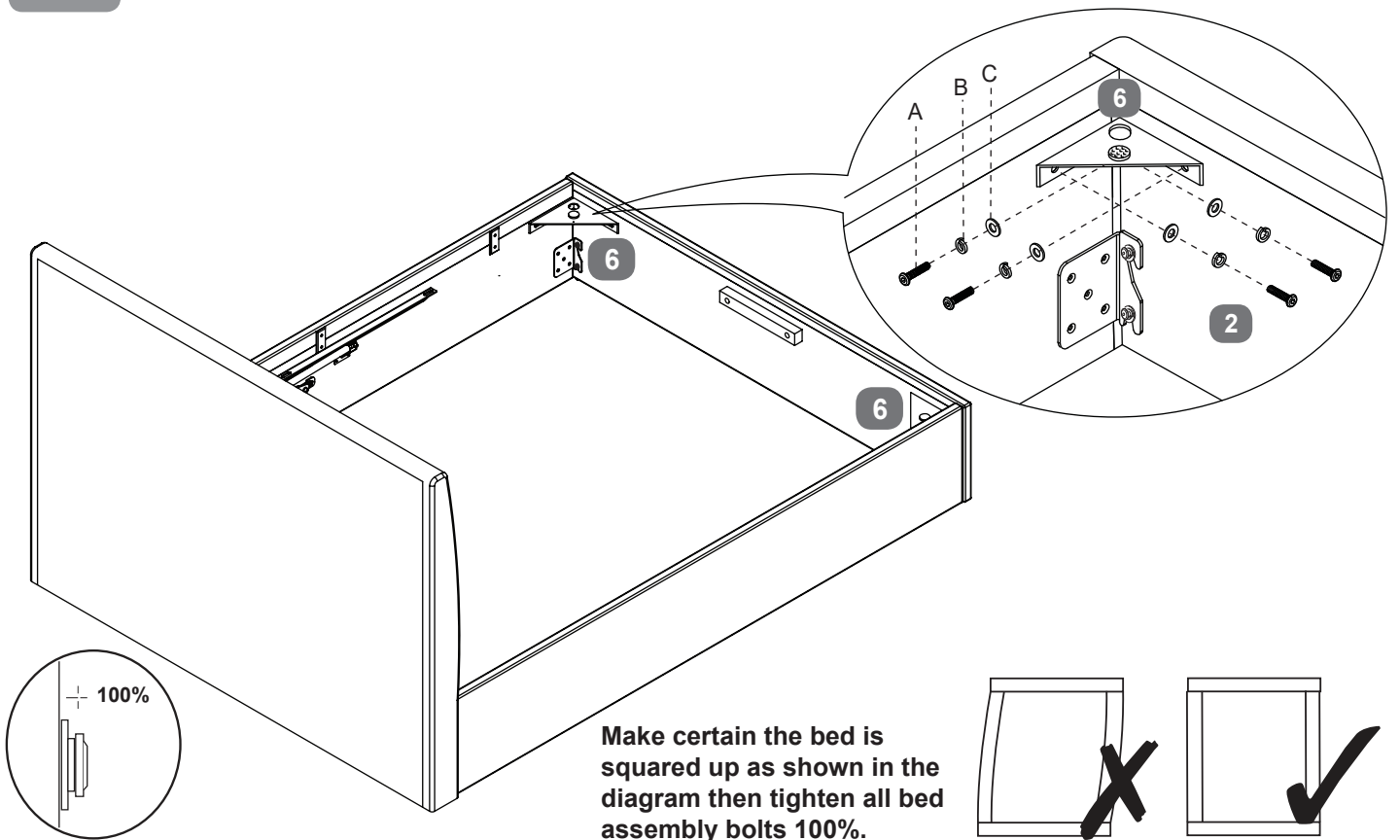

Stage
4

⚠ WARNING CAREFULLY LIFT BOTH HEADBOARD & FOOTBOARD AT THE SAME TIME, DO NOT LET THE BED TWIST

⚠ WARNING

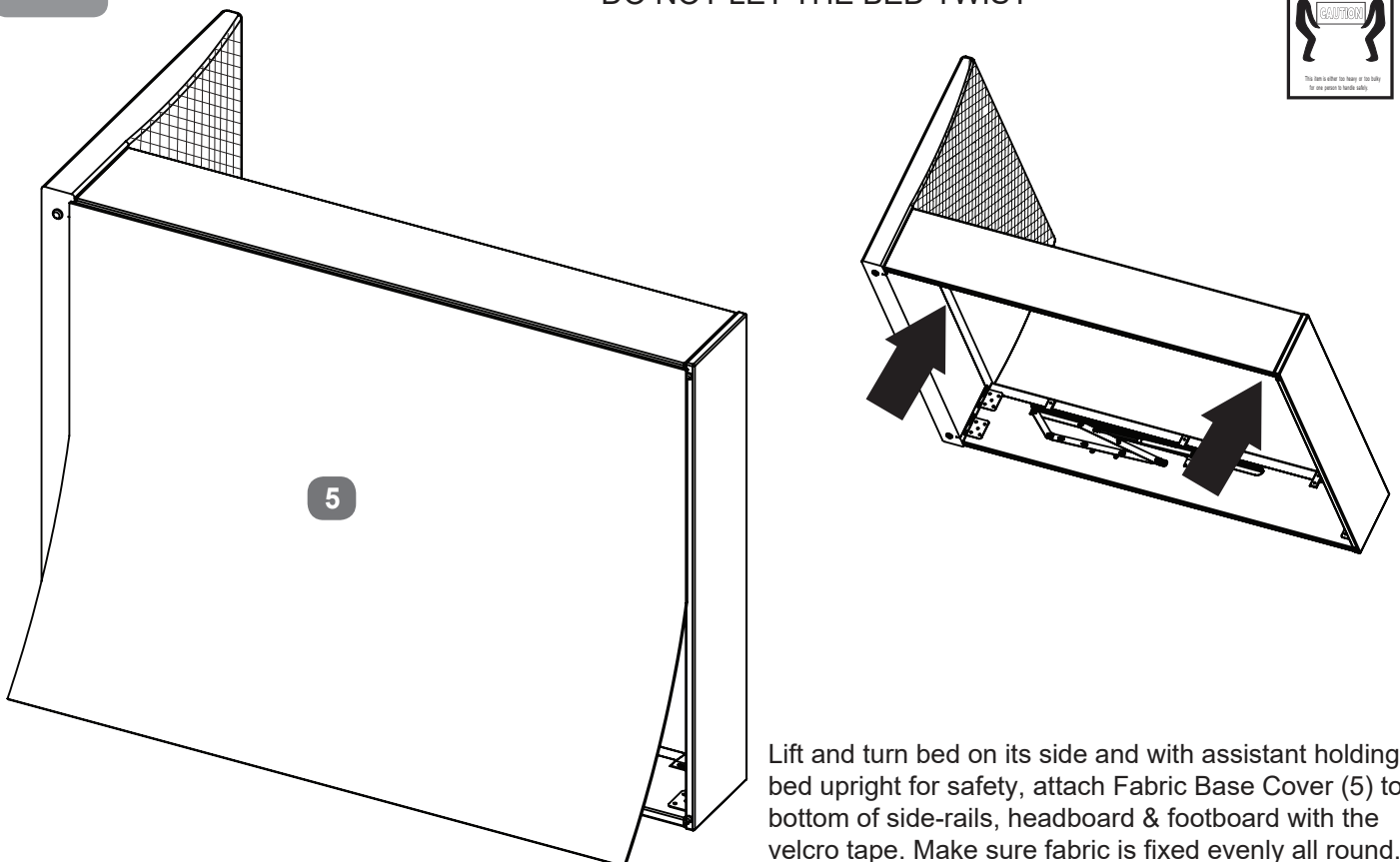

Assembling Slat Frame - Use Pack 'B'

Stage
5

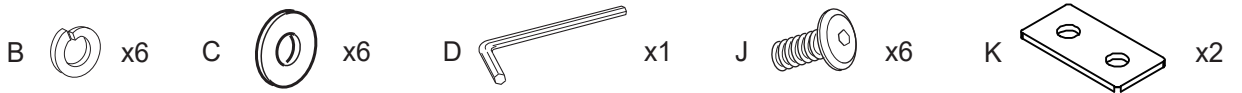

i) Fitting position for cross Bar (9) is clearly labeled. Pass bar through Metal Slat Frame (8) between first & second slat. Carefully open the frame.

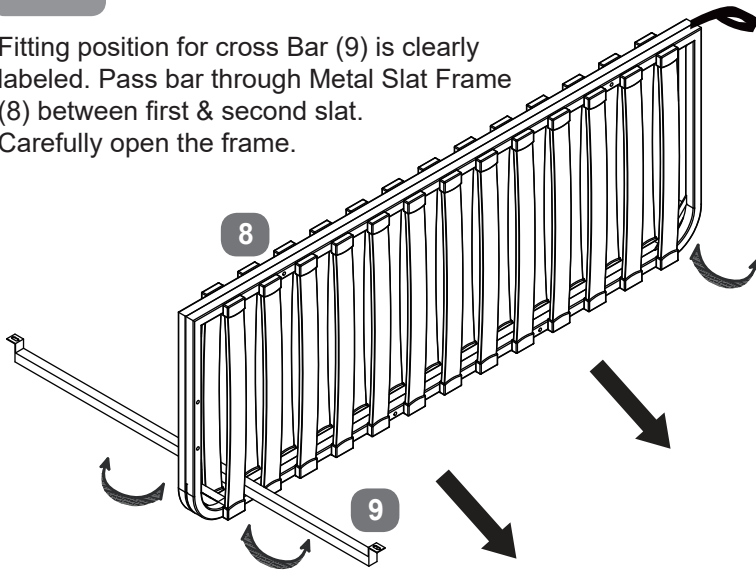

iii) Using four sets of bolts (J), spring washer (B) & flat washers (C) fit two pieces of the metal plate (K) into threaded inserts on top of the frame. Using Allen key (D), tighten all six bolts 100%.

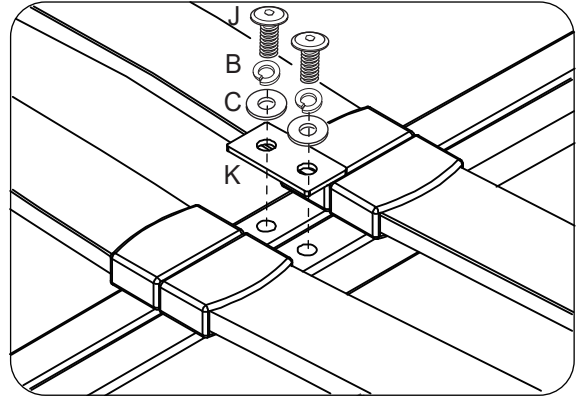

ii) Ease the plates on top of the cross bar (9) onto top of the slat frame sides and loosely fit two sets of bolts (J), spring washers (B) & flat washers (C) through the plates into the threaded inserts. Do not tighten yet.

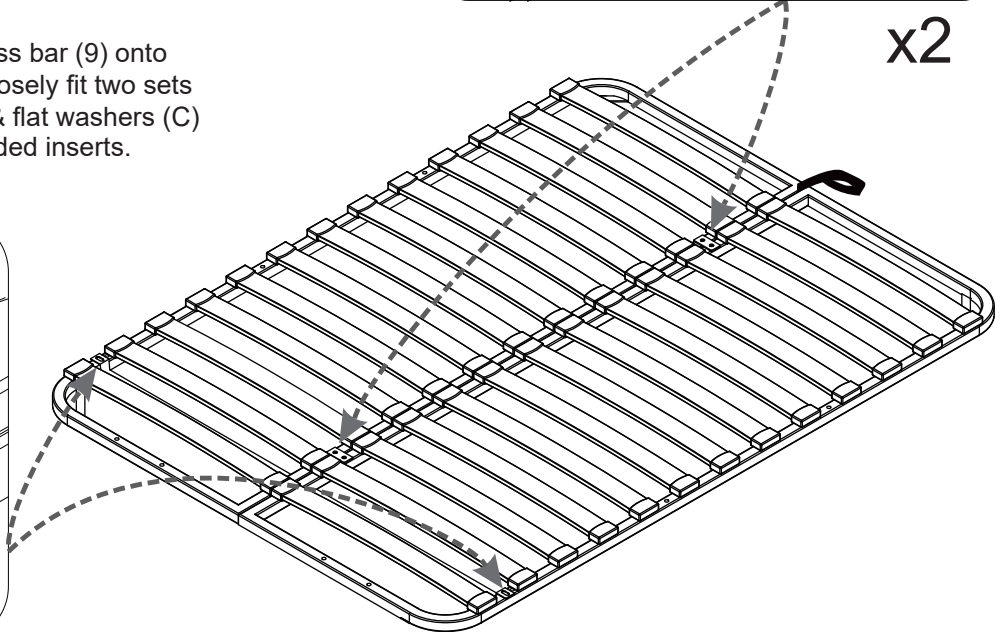
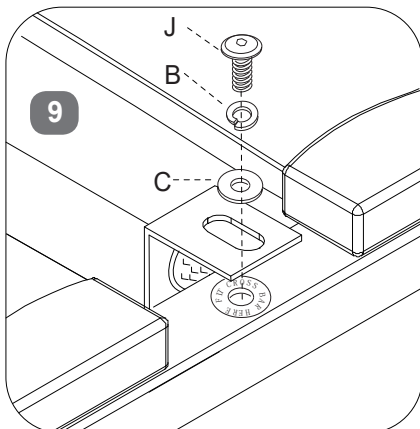

Stage
6

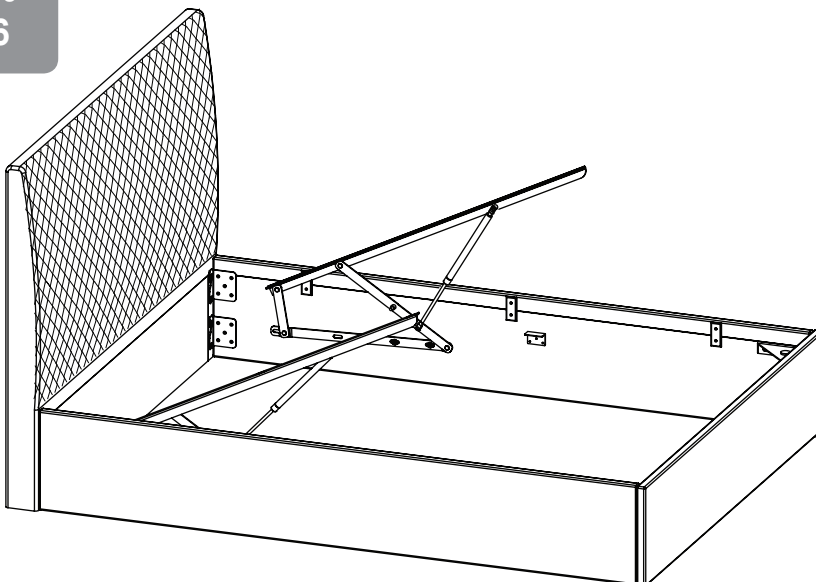

i) UN-TIE THE ONE MECHANISM, AND TAKE OUT THE BLOCK

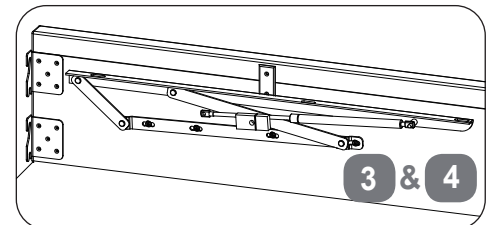

ii) HOLD THEM FORWARD

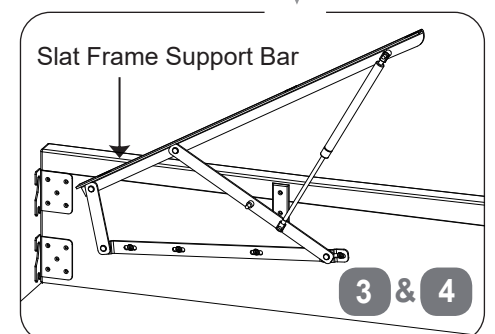

Bed Assembly - Use Pack 'B'

Stage
7

B  x6

C  x12

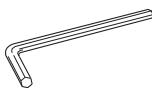
D  x1

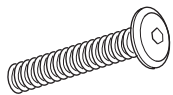
E  x6

F  x6

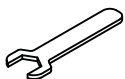
G  x1

i) With help from your assistant, lift slat frame (8) onto slat frame support bars aligning first set of holes on slat frame with first set of holes in support bars (nearest to headboard).

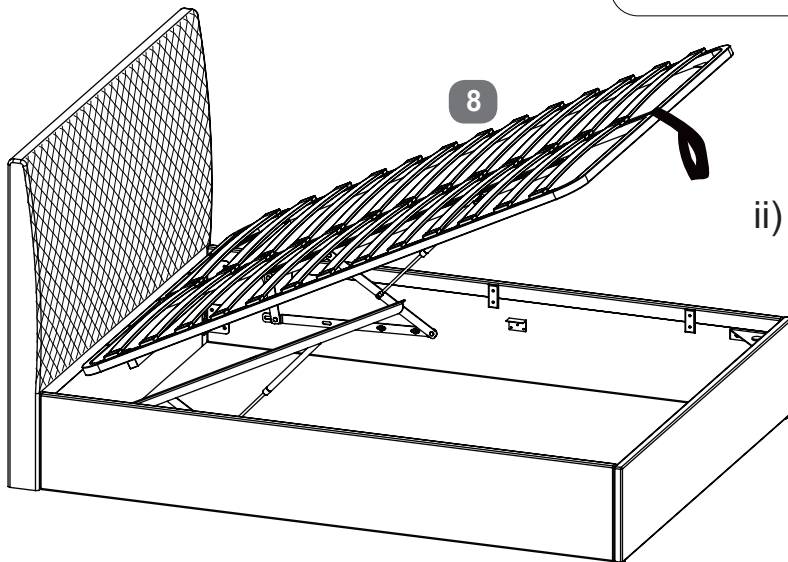
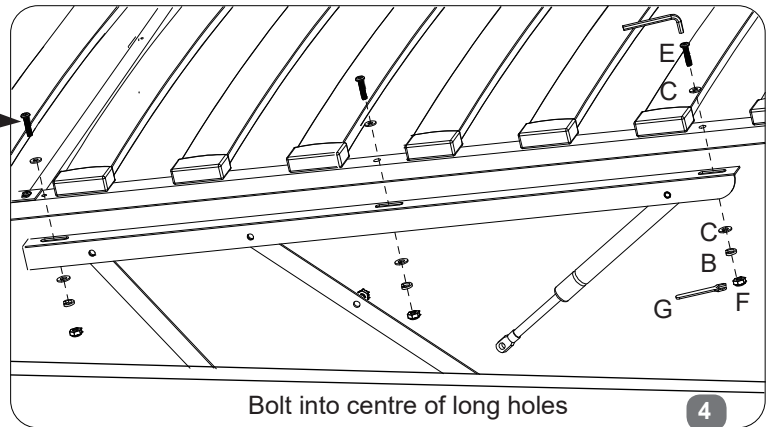

ii) Using three bolt sets on each side (E), (C), (B) & (F), fix slat frame to the support bars but do not tighten fully.

Stage
8

Carefully lay frame down making sure there is an even gap all round as in the sketch.

D  x1

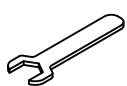
G  x1

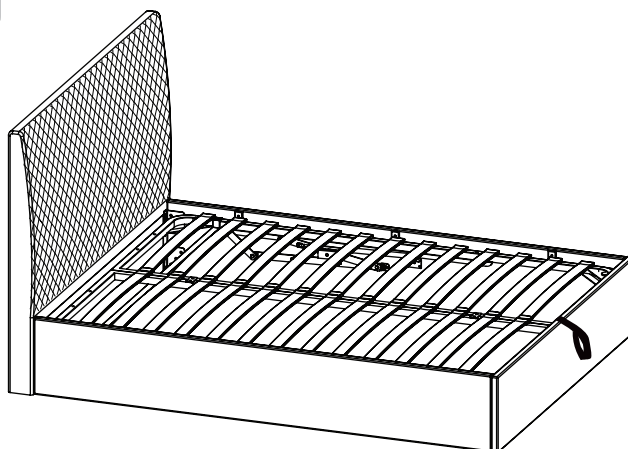

Hold frame securely then tighten all six bolt sets 100% using spanner (G) & Allen key (D).

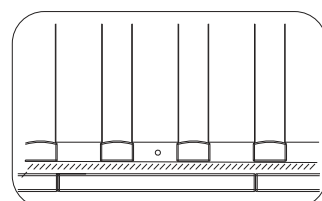

8mm

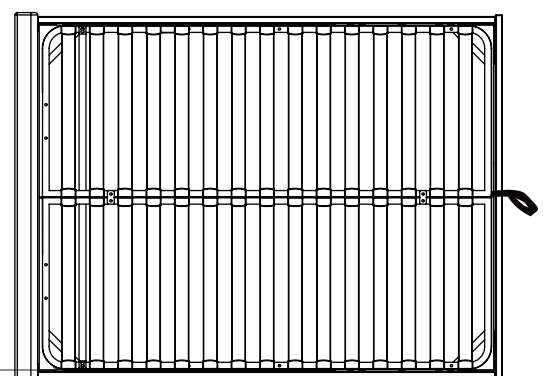

Bed Assembly - Use Pack 'B'

Stage
9

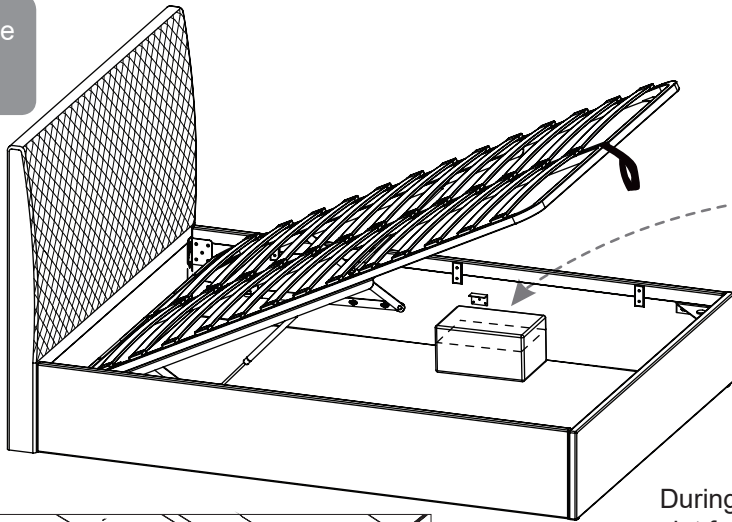

Note: Be very careful what you store under the bed - the top of an item, like a suitcase or a box must not touch the slats or they may be damaged. Maximum storage height is 185mm.

During this next step, the assistant should hold up the slat frame.

On side rails (3&4) slide gas-lift piston stems (X) onto the axles (Y) then fit the flange lock-nuts (H).

Tighten nuts with spanner (H) - BUT DO NOT over-tighten. A small gap is left so stems can move freely - this is important - see sketch below.

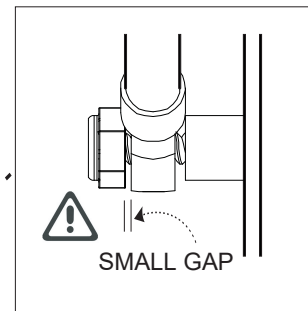
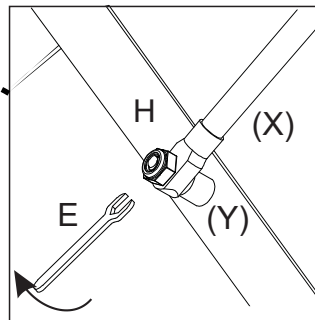
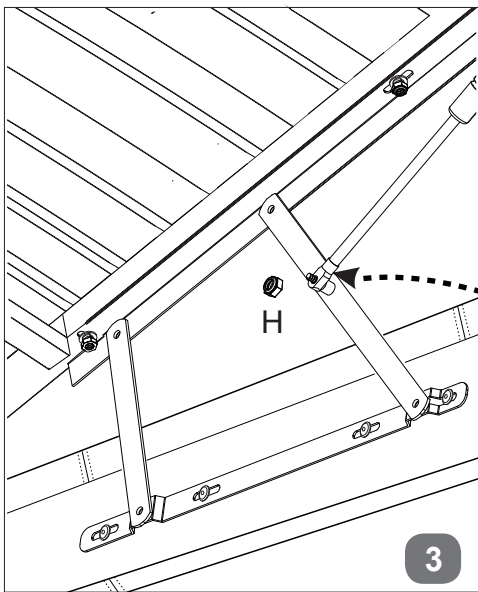

Stage
10

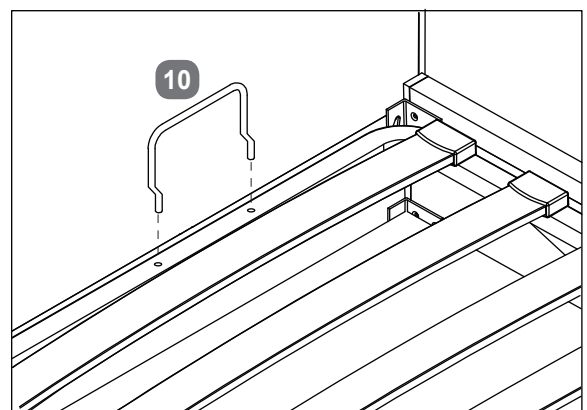
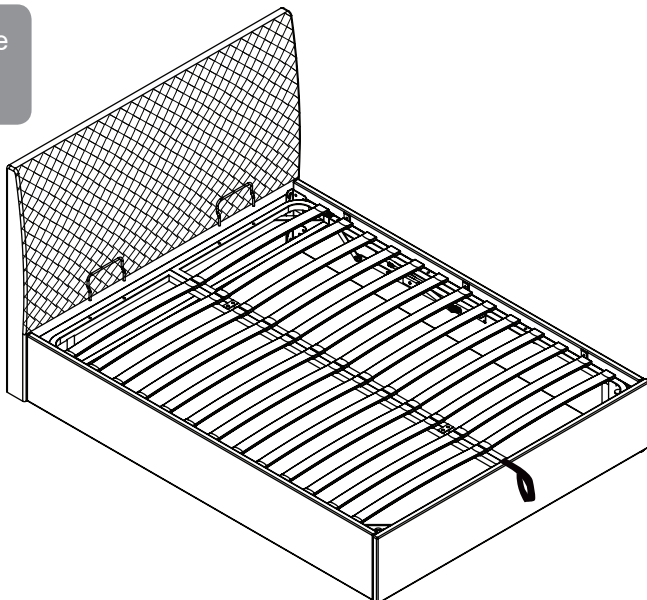

NOTE: Before moving the slat frame, place the mattress on the slats. Without a mattress in place, the speed of movement is quick and may cause injury. Carefully lower the frame with the hand-strap ensuring the frame sides are aligned with the side panels; there should be an even gap on each side. If not aligned, check bed is still square (see Stage 3) and if it is, but gaps are still not even, re-align as in Stage 8.

Depending on the weight of the mattress, the rising speed will vary so be careful until you get used to the speed. Always use the strap to lift or lower the frame - keep fingers well away from the moving parts.

When fully assembled and the mattress in position, please raise & lower the ottoman 4/5 times to ensure the gas pistons are fully lubricated.